

6700 Series Solution & Semimicro Calorimeters



6700



Parr Instrument Company

Founded in 1899
by University of Illinois
Professor S.W. Parr,
Parr Instrument Company
has consistently strived
to provide for its customers
the very best in product,
service and support.

Parr Instrument Company is pleased to feature its Series 6700 line of Calorimetric Thermometers, Solution Calorimeters, and Semimicro Oxygen Bomb Calorimeters. These instruments bring the latest in microprocessor based technology to these specialized applications. The same advances in control, display, and data handling developed for the Parr Series 6000 line of Oxygen Bomb Calorimetry have also been incorporated in this line of calorimeters.

The Model 6772 Calorimetric Thermometer

features a calorimetric thermometer with temperature resolution of 0.0001 °C over a range of 10 to 50 °C. In addition it includes all of the operating controls, heat leak and thermochemical calculations required for automating the Parr 1341 Calorimeter as well as the two calorimeters described below. Modern digital communications (Ethernet and USB) are provided for data transfer to and from the thermometer. **See page 3.**



6772 Calorimetric Thermometer

The Model 6755 Solution Calorimeter

incorporates the 6772 Thermometer and provides a convenient and easy to operate instrument for measuring heats of reaction, mixing, solution, dilution, wetting and similar endothermic or exothermic reactions at ambient temperatures and pressures. The 6772 Thermometer includes the capabilities of determining initial and final equilibriums and determining heat leak corrections by any one of three methods. **See page 4.**



6755 Solution Calorimeter

The Model 6725 Semimicro Calorimeter

incorporates the 6772 Thermometer and offers a high degree of automation and data handling for users who prefer or must work with samples in the 20 to 200 mg range. This calorimeter features the Model 1109A Semimicro Oxygen Vessel. Energetic samples can be tested using the 1109X High Strength Semimicro Vessel. **See page 8.**



6725 Semimicro Calorimeter

The Model 6765 Combined Solution and Semimicro Calorimeter (not shown) provides all of the equipment for running both solution calorimetry and semimicro oxygen bomb calorimetric tests. This is a valuable multi experiment system for physical chemistry instruction. Conversion sets are also available to add the second operating mode to either of the calorimeters. **See page 11.**

Note About Nomenclature:
Historically, burning a sample enclosed in a high pressure oxygen environment is known as Oxygen Bomb Calorimetry and the vessel containing the sample is known as an Oxygen Bomb. The terms bomb and vessel are used interchangeably.

Model 6772 Calorimetric Thermometer

For precise temperature rise measurements and calorimetric determinations control.



6772 Calorimetric Thermometer Displaying Main Menu Screen

This two-channel precision calorimetric thermometer is included with the 6725 Semimicro Oxygen Bomb Calorimeter and the 6755 Solution Calorimeter. It is also used with the Parr 1341 Oxygen Bomb Calorimeter or for other laboratory applications requiring high precision, differential temperature measurements.

The 6772 Calorimetric Thermometer features Parr's new fourth generation microprocessor control and provides:

- A bright, color, touch screen display and data input system with an intuitive graphical user interface for instrument setup and operation.
- A modern operating system (Linux) with communication and file management systems comparable to a PC.
- USB port for reporting to a printer, receiving sample weights from an analytical balance and bidirectional communications with a laboratory computer via an Ethernet connection.
- A built-in ignition circuit for manually or automatically firing an oxygen bomb.

The Operating Program provides the user with many options and provisions for:

Calorimeter Operation

- Oxygen bombs
- Solution

Thermal Corrections

- Calculated
- Fixed
- Measured – using a second probe

Temperature Graphing

- On screen
- Remote

Thermochemical Corrections (Combustion)

- Fuse
- Nitric Acid
- Sulfur

Data Entry

- Manual
- Automatic

Reporting Controls

Communications Controls

- Diagnostic
- Help menus

SPECIFICATIONS

Model Number:
6772

Operating Range:
10 - 50 °C

Resolution:
0.0001 °C

Absolute Accuracy
w/out Calibration:
± 0.1000 °C

Absolute Accuracy
w/ Calibration:
± 0.0500 °C

Repeatability, Single Point:
± 0.002 °C

Linearity, 10 °C Span:
± 0.002 °C

Balance Communication:
USB

Printer Communication:
USB

Network Connection:
TCP/IP via Ethernet

Dimensions (cm):
56w x 36d x 31h

6772 Calorimetric Thermometer Ordering Guide

Model No.	Voltage	Description
6772EA / EF	115 V / 230 V	6772 Calorimetric Thermometer
1168E2	NA	Thermistor Probe

Model 6755 Solution Calorimeter

For measuring enthalpy changes produced by chemical reactions in solution.

SPECIFICATIONS

Model Number:
6755

Precision Classification:
0.4 Class (1.5 – 5.0 °C rise at or near room temperature)

Working Temperature Range:
10 – 50 °C

Temperature Sensitivity:
0.0001 °C

Energy Measurement Range:
2 – 1000 calories

Energy Equivalent:
100 – 145 Calories/°C

Maximum Volume, Solute:
20 mL

Required Volume, Solvent:
90 – 120 mL

Balance Communication:
USB

Printer Communication:
USB

Network Connection:
TCP/IP via Ethernet

Dimensions (cm):
6755: 22w x 33d x 33h
6772: 56w x 36d x 31h



6755 Solution Calorimeter shown with 6772 Calorimetric Thermometer

A Multi-purpose Calorimeter

Utilizing a unique rotating sample cell and a precise microprocessor-based thermometer, the Parr 6755 Solution Calorimeter provides a moderately priced and easily operated instrument for measuring:

- Heats of Reactions
- Heats of Mixing
- Heats of Solution
- Heats of Dilution
- Heats of Wetting

Measurements are made at ambient temperature and at atmospheric pressure in either liquid-liquid or liquid-solid systems covering energy changes ranging from 2 to 1000 calories. All operations are straightforward and simple, using a built-in, microprocessor-based thermometer for precise temperature measurements. The calorimeter is controlled from a touch screen LCD panel on the 6772 Calorimetric Thermometer. Communication ports are provided for optional printers, computers and/or laboratory data networks.

Many Uses

There are many uses for this convenient, bench-top calorimeter:

- As a research instrument it offers a convenient and rapid means for obtaining basic chemical data with a precision that will be adequate for most preliminary research and exploratory applications.
- As an analytical tool it has many applications in industrial laboratories for product evaluation and quality control. Such applications may extend beyond the range of pure calorimetry to include tests in which there is a direct relationship between the heat of reaction and a chemical or physical property of one of the reactants in a system.
- As a teaching instrument it has an important place in college and university lab-oratories for demonstrating and teaching the fundamentals of thermochemistry.

Many Different Reactions

Any liquid-liquid or liquid-solid chemical reaction in which heat is evolved or absorbed within a temperature range from 10 to 50 °C can be studied in the 6755 Calorimeter.

Heats of Reaction, either endothermic or exothermic, can be determined in many different systems, ranging from simple acid-based reactions to more complicated redox, chelation, hydrolysis, protonation and other reactions. The calorimeter is particularly effective for assays of weak acids and weak bases which do not respond readily to other detection methods. It can also be used for rapid specific ion determinations by thermochemical methods as best illustrated by determination of sulfur using barium chloride to precipitate barium sulfate from a sulfate solution.

The heat of solution produced when a solid dissolves in a liquid can be measured easily. Similarly, the calorimeter can be used to measure the heat of dilution produced by diluting a solution with solvent or with a solution of a lower concentration. It will also measure the heat of mixing, produced when two liquids are combined.

The heat of wetting as measured with this calorimeter serves not only as a thermochemical measurement, but also as a rapid method for determining the surface area of a powdered solid, since the heat released when a powder is treated with a wetting agent will be proportional to the exposed surface area.

A Well Insulated Reaction Chamber

All reactions in the 6755 Calorimeter are conducted in a fully silvered glass Dewar. The Dewar is supported within a stainless steel air can from which it is easily removed for filling or cleaning. A block of plastic foam surrounds the air can, with the entire assembly mounted in a rugged aluminum case.

A Unique, Rotating Sample Cell

A closed glass bell with a detachable bottom holds a solid or liquid sample in the Dewar and also serves as the stirrer for the calorimeter system. The bottom of the cell is closed with a PTFE dish which fits snugly into the bell without requiring a gasket or sealing ring. Solid samples (up to 2 grams) can be weighed directly into this dish before it is attached to the bell. Liquid samples (up to 20 mL) can be added to the closed cell from a pipet inserted through the top stem.

Continued on next page >

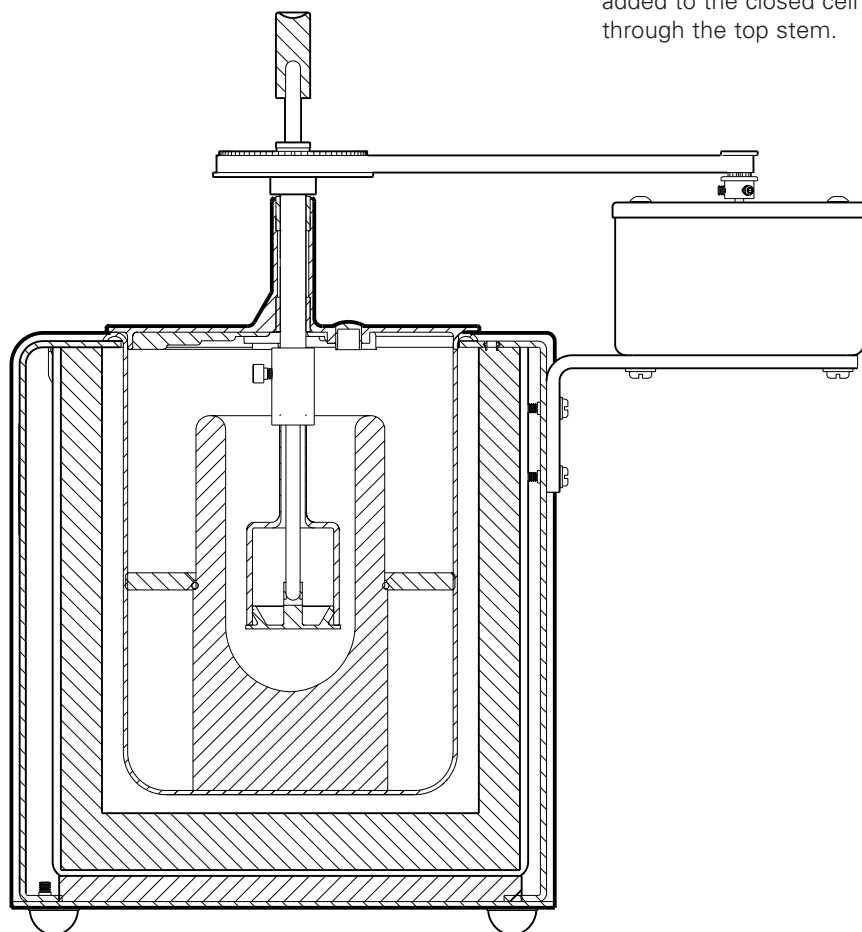

6755 Calorimeter Cross Section



A130C Sample Cell with 126C Bottom Dish

Model 6755 Solution Calorimeter, continued

To start the reaction, a glass push rod is inserted from the top of the calorimeter through the stirring shaft and into a socket in the sample dish. When this rod is pushed downward, the dish slides out of the cell and remains attached to the rod, held at a fixed distance above the bottom of the reaction vessel. In this position the rod and dish rotate with the cell, slinging the reactants into the solution and serving as an additional impeller in the stirring system.

Heat leak from the cell to the non-wetted parts of the system is held to a minimum by a low conductivity, thin walled glass stem on the sample cell and a plastic coupling which fastens the cell to the stirring shaft. The cell is easy to load, easy to clean and, if broken, it can be replaced at minimum expense since the sample dish and other parts are interchangeable. The dish itself is made of PTFE reinforced with glass fiber for excellent resistance to most chemical agents and good dimensional stability.

The Stirrer Drive

The stirring mechanism consists of an externally mounted electric motor with a drive belt which turns the stirring shaft at a constant speed (approximately 450 rpm) with no slippage and very little bearing friction. The hollow drive shaft terminates at the underside of the calorimeter cover where it joins the low conductivity coupling on the end of the sample cell.

Easy to Operate

The operation of the 6755 Calorimeter is quite simple. At the start of a test, one liquid is held in the glass Dewar while the other reactant, either solid or liquid, is held in the sealed rotating cell which is immersed in the first liquid. The system comes to equilibrium quickly with only a slight temperature drift from the heat of stirring and from any heat leak into or out of the calorimeter. After recording the initial drift and without interrupting the rotation of the sample cell, the operator starts the reaction by depressing the push rod which drops the content of the cell into surrounding liquid. The reaction then proceeds to completion under the vigorous stirring action of the rotating cell.

Precision Thermometry

Temperatures in the Dewar are measured with a Parr 6772 Calorimetric Thermometer (described in detail on page 3) which is included with the 6755 Calorimeter. Readings are taken with a thermistor sealed in a stainless steel probe. Although the thermometry section has a working range

from 10 to 50 °C, best calorimetric results are obtained when working within ± 5.0 °C of room temperature, since the system depends on a glass Dewar for controlling the heat leak.

The thermometer in the calorimeter can also be used for general purpose, high precision temperature measurement in other apparatus, using a thermistor probe in a stainless steel sheath for measurements in the 10 to 50 °C range.

Data Collection and Display

The 6772 Calorimetric Thermometer has an onboard data logging capability which will store data in the instrument for later transfer to a computer or to a printer.

The software built into the calorimeter can provide temperature rise data which has been corrected for heat leaks and the heat of stirring in the system or, it can provide uncorrected temperature readings for manual, computer or graphical analysis.

A Parr 1759 Printer is offered for users who wish to take full advantage of the onboard calculation capabilities of the calorimeter. This is a compact, 40-column printer which will produce a printed record of all calorimetric data when called up by the user. A standard USB port is provided for the printer connection. Users who already have a comparable printer can use it with this connection.

Computers can also be connected to the Ethernet communications port. This option will be attractive to those who wish to use spreadsheets to write their own data collection and reduction programs, or those who wish to plot thermograms for graphical analysis. A fully configurable charting program is provided for the calorimeters LCD display.

Precision

The precision obtainable with the 6755 Solution Calorimeter will be a function of the amount of heat liberated by the reactants and the temperature at which the test is conducted. The best precision will be obtained when working with reactions which release between 200 and 600 calories, producing a temperature rise of 1.5 to 5.0 °C at or near room temperature. Under these conditions a standard deviation of less than 0.4 percent of the determined value can be obtained in repetitive tests. If the total heat release produces a rise of less than 0.5 °C or more than 6.0 °C, or if the test is conducted at higher working temperatures with significant heat leak, the relative standard deviation may increase to 1.0 percent of the determined value.

Standardization

Three different procedures are available for standardizing the calorimeter:

Chemical Standardization is readily accomplished using a precise, reproducible exothermic reaction of TRIS — tris(hydroxymethyl)aminomethane — with 0.1 N HCl in a NIST procedure which is described in the instructions furnished with the instrument. A 100-gram bottle of TRIS is furnished with the calorimeter for this purpose. Additional supplies can be obtained from Parr, or the basic reference material may be purchased from the National Institute of Standards and Technology.

Comparison Standardization involves the use of known samples supplied by the user. By selecting samples whose enthalpy changes are known and whose thermochemical behavior is similar to the unknown material, the calorimeter can be standardized by simply running duplicate tests with known and unknown materials.

Electrical Standardization requires an electric heating probe, a uniform power supply, a high precision voltmeter and a precise interval timer. With the exception of the heating probe (Part No. A274C), this equipment is not sold by Parr, but most of the items can be obtained from commercial sources.

Standard Parts

Each 6755 Solution Calorimeter consists of a Dewar reaction vessel in an insulated housing with a glass sample cell and sample dish, push rod, thermistor probe, stirrer drive motor and a calorimetric thermometer. One extra sample cell with a dish and one 100 gram bottle of Parr Standard TRIS are furnished with the calorimeter.

Conversion Parts

A conversion set consisting of all parts needed to convert a 6755 Solution Calorimeter to a 6725 Semimicro Bomb Calorimeter is available. See page 11 of this catalog for details.

6755 Solution Calorimeter Ordering Guide

Model No.	Description
6755EA	6755 Solution Calorimeter, 115V
6755EF	6755 Solution Calorimeter, 230V
A274C	Heating Probe (for electrical standardization, contact Parr technical support)
6765EA / EF	Combined Solution and Semimicro Calorimeter

6755 Solution Calorimeter Available Spare Parts

Part No.	Description
A130C	Combined Solution and Semimicro Calorimeter
126C	Heating Probe (for electrical standardization, contact Parr technical support)
A129C	Combined Solution and Semimicro Calorimeter
123C	Heating Probe (for electrical standardization, contact Parr technical support)
3421	6729 Conversion Package 6755 to 6725

The 1759 Printer

For users who prefer to have a dedicated printer at the calorimeter, Parr offers the Model 1759 Printer. The 1759 is a compact, dot matrix printer set up for 40-column reports. It is housed in a separate case 6.5-inches wide, 10-inches deep and 6-inches high and operates from its own power supply. The 1759 is furnished with all the standard parts and accessories listed in the ordering guide which are also available for purchase separately.

1759 Printer Ordering Guide

Model No.	Description
1759EA	Printer and Cable, 115V
1759EF	Printer and Cable, 230V
334C	Printer Paper
335C	Printer Ribbon
A2170E	Printer Cable, USB

Model 6725 Semimicro Bomb Calorimeter

The 6725 Semimicro Bomb Calorimeter for measuring the calorific value of small combustible samples.

SPECIFICATIONS

Model Number:
6725

Tests Per Hour:
2 – 3

Operator Time Per Test:
6 – 10 Minutes

Precision Classification:
0.4% Class

Jacket Type:
**Compensated,
Dewar Flask**

Oxygen Fill:
Manual

Bucket Fill:
Manual

Bomb Model Options:
**1109A, 22mL Manual
Valve, Semimicro
1109X, 22mL High
Strength, Semimicro**

Balance Communication:
USB

Printer Communication:
USB

Network Connection:
TCP/IP via Ethernet

Dimensions (cm):
**6725: 22w x 33d x 33h
6772: 56w x 36d x 31h**



6725 Semimicro Calorimeter shown with 6772 Calorimetric Thermometer

The 6725 Semimicro Bomb Calorimeter is a compact and easily operated, static jacket, combustion calorimeter designed specifically for measuring the heat produced by the combustion of small samples when only limited amounts of test material are available. It is equally useful for procedures in which it would be difficult to obtain a measurable temperature rise in a standard calorimeter, or where the nature of the sample makes semimicro operation desirable.

Many Applications

The ability of the 6725 Calorimeter to produce complete combustion and a measurable temperature rise with small samples in the 25 to 200 mg range makes this an excellent instrument for use in marine biology and related ecological studies where only limited amounts of sample are available. It also can be used for testing a variety of heat powders and pyrotechnic mixtures, particularly slow burning thermite types which are used to produce heat. Samples which contain their own oxidizers can be burned in an inert atmosphere,

while others can be burned in oxygen. There is, however, an important limitation to be observed: the 6725 Calorimeter must not be used for testing self-oxidizing samples if the reaction liberates a considerable amount of gas, due to the dangerous high pressures which might develop within the bomb.

A 22 mL Oxygen Bomb

The 1109A Oxygen Bomb used in the 6725 Calorimeter is the smallest of all Parr oxygen bombs. This 22 mL bomb will handle samples ranging from 25 to 200 mg, liberating up to 1200 calories when burned in oxygen, using initial oxygen pressures up to 35 atmospheres. Outputs up to 2400 calories can be accommodated if the sample is self-oxidizing, provided it is burned in an inert atmosphere and does not produce gas. Combustion in oxygen must be limited to a maximum output of 1200 calories.

The 1109A Semimicro Oxygen Bomb is a manual sealing design. The head is equipped with an inlet/outlet valve for oxygen filling and release, and insulated and grounded electrodes for the firing circuit.

Samples are held in a shallow Inconel dish which is supported on an adjustable Ni-Cr loop attached to the oxygen inlet tube. Electrical connections for the firing circuit are made through a connector which slides into the central terminal and bomb support stand.

The 1109X High Strength Semimicro Oxygen Combustion Bomb is also available for use in the 6725 Calorimeter. The 1109X is similar in most aspects as the 1109A Vessel but has been specially strengthened to be suitable for testing energetic materials and it is optimized for the measurement of small energy releases.

The Oxygen Connection

Oxygen is supplied to the 1109A Bomb with a Parr 1824 Filling Connection which provides all of the valves and fittings needed to fill the bomb from a commercial oxygen tank, including an automatic relief valve to prevent overcharging.

An Effective Thermal Jacket

Effective static insulation is provided in these calorimeters by using a fully silvered glass Dewar as the calorimeter vessel. This vacuum flask holds the 1109A Semimicro Bomb in 460 grams of water. It is supported within a stainless steel air can which is easily removed for filling or cleaning. The air can is surrounded by a plastic foam block, and the entire assembly is mounted in a sturdy aluminum case.

A thermistor probe and stirrer are mounted on the calorimeter cover and remain attached to the cover when the calorimeter is opened. A small motor attached to the side of the case drives the stirring shaft at a constant speed (approx. 450 rpm) through a flat, ribbed drive, belt which is easily removed when opening the calorimeter.

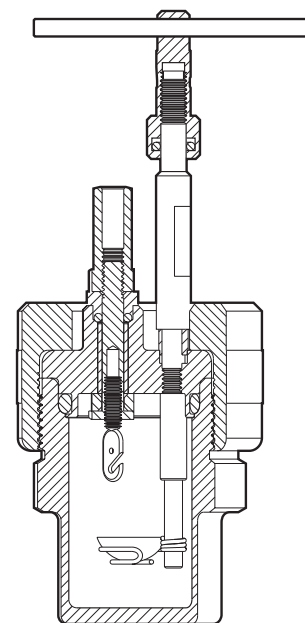

Cross Section of 1109A Bomb



1109A Semimicro Oxygen Bomb

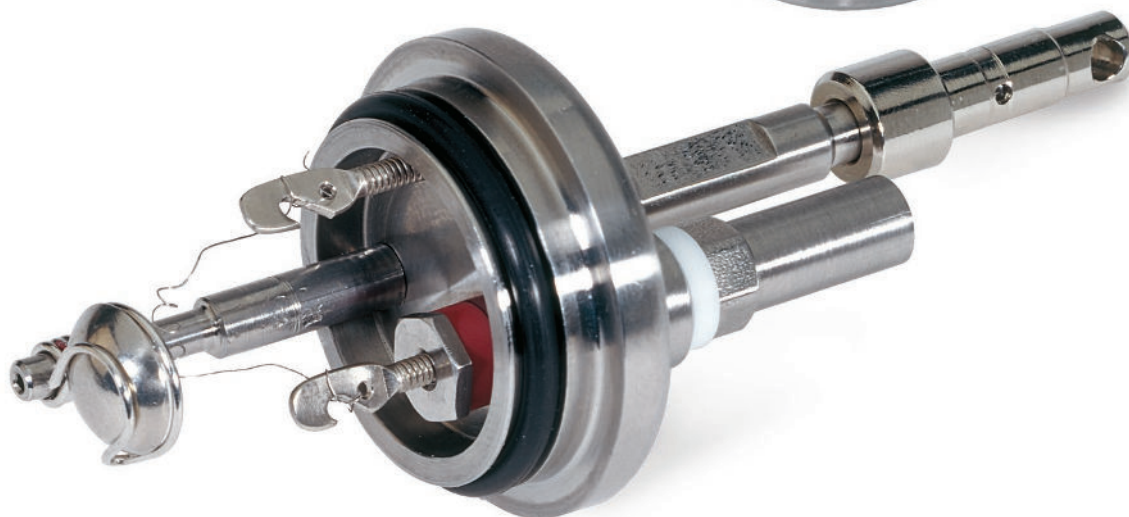

Model 6725 Semimicro Bomb Calorimeter, continued

Precise temperature measurements in the 6725 Semimicro Calorimeter are taken with a Parr 6772 Calorimetric Thermometer which is described on page 3. In this application, the thermometer module is included with the calorimeter.

Good Precision

The precision obtainable with the 6725 Calorimeter will depend primarily upon the amount of energy released by the sample. If the release is less than 100 calories, the deviation from the mean will not exceed 1.0 percent of the measured value. With a 400 calorie release, the deviation will be less than 0.4 percent of the mean value.

6725 Semimicro Calorimeter Standardization

A supply of 0.2 gram standard benzoic acid pellets is provided for standardizing the calorimeter.

Conversion to a Solution Calorimeter

Since the case, thermometer and motor drive for the 6725 Semimicro Calorimeter are the same as used for the 6755 Solution Calorimeter, the semimicro model can be converted to a solution calorimeter by simply replacing the inner parts with solution calorimeter components. Or, semimicro components can be installed in a solution calorimeter case. Conversion parts for these changes are listed on page 11.

Standard Accessories

The 6725 Semimicro Calorimeter is furnished with an attached digital calorimetric thermometer and the following standard parts and accessories:

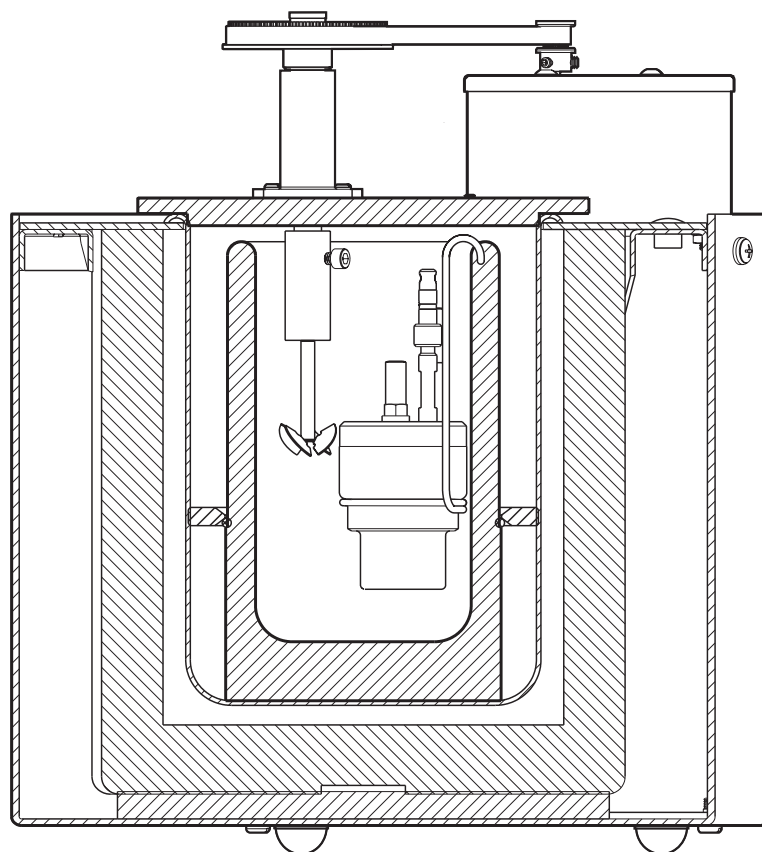

6725 Calorimeter Cross Section

6725 Standard Parts and Accessories

Model No.	Quantity	Description
1109A	1	Semimicro Oxygen Bomb
1824	1	Oxygen Filling Connection
208AC	1	Inconel Fuel Capsule (Package of 2)
45C10	1	Fuse Wire, 10 cm Card (Package of 3)
3414	1	Vial of 100, 0.2 g Benzoic Acid Pellets

Plus a supply of extra gaskets and sealing rings for the 1109A Bomb and operating instructions for the 6725 Semimicro Calorimeter.

Optional Accessories

Model No.	Description (Select part no. for voltage required)
A535A	Support Stand
1759EA	Printer and Cable, 115V
1759EF	Printer and Cable, 230V
534A	Service Clamp
A2170E	Printer Cable, USB

6725 Ordering Guide

Model No.	Description (Select part no. for voltage required)
6725EA	Semimicro Calorimeter with Standard Accessories, 115V
6725EF	Semimicro Calorimeter with Standard Accessories, 230V

6765 Combined Solution and Semimicro Calorimeter

For laboratories that want to perform both Solution and Semimicro Oxygen Bomb calorimetry tests, Parr offers the 6765 Combined Calorimeter. This includes the 6772 Calorimetric Thermometer module plus a calorimeter module and conversion parts for both the 6755 Solution Calorimeter and the 6725 Semimicro Calorimeter. This option has been popular with teaching laboratories that wish to include both types of experiments in their laboratory sessions.

Conversion Sets

The 6729 and 6759 Conversion Sets are also available for users who have one of the principle calorimeters and wish to add the second capability to their installation.



6725 Semimicro Calorimeter with Accessories

6765 Ordering Guide

Model No.	Description (Select part no. for voltage required)
6729	Conversion Set for Changing a 6755 Solution Calorimeter to a 6725 Semimicro Calorimeter
6759	Conversion Set for Changing a 6725 Semimicro Calorimeter to a 6755 Solution Calorimeter
6765EA	Solution and Semimicro Calorimeter Combined, 115V
6765EE	Solution and Semimicro Calorimeter Combined, 230V

6729: To Convert from 6755 to 6725

All of the parts needed to convert a 6755 Solution Calorimeter to a 6725 Semimicro Bomb Calorimeter are provided in a 6729 Conversion Set, including:

Part No.	Quantity	Description (Select part no. for voltage required)
1109A	1	Semimicro Oxygen Bomb
123C2	1	Dewar Flask with Locating Ring and O-ring
A120C2	1	Calorimeter Cover Assembly with Bearing Tower
1824	1	Oxygen Filling Connection
208AC	1	Inconel Fuel Capsule (Package of 2)
45C10	1	Fuse Wire, 10 cm Card (Package of 3)
3414	1	Vial of 100, 0.2 g Benzoic Acid Pellets

Plus a supply of extra gaskets and sealing rings for the 1109A Bomb and operating instructions for the 6725 Semimicro Calorimeter.

6759: To Convert from 6725 to 6755

All of the parts needed to convert a 6725 Bomb Calorimeter to a 6755 Solution Calorimeter are provided in a 6759 Conversion Set, including:

Part No.	Quantity	Description (Select part no. for voltage required)
123C	1	Dewar Flask with Locating Ring and O-ring
A120C	1	Calorimeter Cover Assembly with Bearing Tower
A129C	1	Glass Push Rod
A130C	2	Cell Assembly without Cell Bottom
126C	2	Cell Bottom, PTFE
3421	1	TRIS, Parr Standard, 100 g Bottle

The Parr Limited Warranty

Parr Instrument Company (Parr) combustion bombs, calorimeters, reactors, pressure vessels and associated products are designed and manufactured only for use by or under the direct supervision of trained professionals in accordance with specifications and instructions for use supplied with the products. For that reason, Parr sells only to professional users or distributors to such users. Parr produces precision equipment and associated products which are **not intended for general commercial use.**

EXCLUSIVE WARRANTY

To the extent allowed by law, the express and limited warranties herein are the sole warranties. **Any implied warranties are expressly excluded**, including but not limited to implied warranties of merchantability or fitness for a particular purpose.

WARRANTY CONDITIONS:

- 1. Non-assignable.** The warranties herein extend only to the original purchaser-user and to the distributors to such users. These warranties or any action or claims based thereon are **not assignable or transferable.**
- 2. Use of product.** The warranties herein are applicable and enforceable only when the Parr product:
 - a. Is installed and operated in strict accordance with the written instructions for its use provided by Parr.
 - b. Is being used in a lawful manner.
 - c. Has not been modified by any entity other than Parr Instrument Company.
 - d. Has been stored or maintained in accordance with written instructions provided by Parr, or if none were provided, has been stored and maintained in a professionally reasonable manner.
- 3. The user's responsibility.** Parr engineers and sales personnel will gladly discuss available equipment and material options with prospective users, but the final responsibility for selecting a reactor, pressure vessel or combustion bomb which has the capacity, pressure rating, chemical compatibility, corrosion resistance and design features required to perform safely and to the user's satisfaction in any particular application or test must rest entirely with the user – not with Parr. It is also the user's responsibility to install the equipment in a safe operating environment and to train all operating personnel in appropriate safety, operational and maintenance procedures.

- 4. Warranty period.** Unless otherwise provided in writing by Parr, the warranties herein are applicable for a period of one year from date of delivery of the product to the original purchaser/user. Note, however, that there is no guarantee of a service life of one year after delivery.
- 5. Notification.** To enforce any express warranty created herein, the purchaser/user must notify Parr in writing within thirty (30) days of the date any defect is detected. Upon request of Parr, the part or product involved must be returned to Parr in the manner specified by Parr for analysis and non-destructive testing.

EXPRESS WARRANTIES

Subject to the above Conditions, Parr expressly warrants that its products:

1. Are as described in the applicable Parr sales literature, or as specified in Parr shipping documents.
2. Will function as described in corresponding Parr sales bulletins or, for specially engineered assemblies, as stated in the sales proposal and purchase agreement.
3. Will remain free from defects in materials and workmanship for the Warranty Period.

LIMITATIONS ON THE PARR WARRANTY

As to the original purchaser/user and to the distributors to such users, Parr limits its liability for claims other than personal injury as follows:

- 1. Replacement or repair.** With respect to express warranties herein, Parr's only obligation is to replace or repair any parts, assemblies or products not conforming to the warranties provided herein.
- 2. Disclaimer of consequential damages.** In no event shall Parr be liable for consequential commercial damages, including but not limited to: damages for loss of use, damages for lost profits, and damages for resulting harm to property other than the Parr product and its component parts.

INDEMNITY AND HOLD HARMLESS

Original purchaser-user agrees to indemnify and hold Parr harmless for any personal injuries to original purchaser-user, its employees and all third parties where said injuries arise from misuse of Parr products or use not in accordance with specifications and instructions for use supplied with the Parr products.



Parr Instrument Company

211 Fifty Third Street Moline, Illinois 61265-1770

1-800-872-7720 | 1-309-762-7716 | parr@parrinst.com | www.parrinst.com